

OPERATION, AND MAINTENANCE MANUAL

BULLET TRAP DRAG CONVEYOR INFORMATION MAYFRAN 2 1/2" Pitch Drag Conveyor



Mayfran International, Incorporated

P.O. Box 43038

6650 Beta Drive

Cleveland, Ohio 44143

(440) 461-4100 tel.

(440) 461-5565 fax

TABLE OF CONTENTS

Drag Conveyor information	1
Safety information	2
Safety Information	3
Startup procedures	4
General instructions and rules prior to equipment start-up	4
Maintenance & Adjustments	5
Maintenance schedule	5
Lubrication	6
Gear reducer	6
Adjustments	7
Belt chain adjustment.....	7
Tightening the belt chains	7
Loosening the belt chains.....	8
Spare Parts	9
Trouble shooting	10
Overview	10
Overload faults	10
Troubleshooting guide.....	10

BULLET TRAP DRAG CONVEYOR INFORMATION

MACHINE INFO

Customer: _____

Mfg. Year: _____

Serial No: _____

Voltage/Phase _____

Cycle: _____

Inspected by: _____

YOUR WARRANTY PERIOD

Mayfran's Warranty is given on the following page.

Your Warranty period: _____ through _____

CUSTOMER SERVICE / PARTS ORDERS

If you have any questions or need to order parts, please contact Mayfran International at:
(440) 461-4100 Fax: (440) 461-5565 8:00 a.m. to 5:00 p.m. (EST)

THIS GUIDE IS COPYRIGHTED

All rights are reserved. This manual may not, in whole or in part, be copied, photocopied, reproduced or reduced to any form of electronic medium or machine readable form without prior consent, in writing from:

Mayfran International, Incorporated
P. O. Box 43038
Cleveland, OH 44143

Information in this manual is subject to change and is furnished to supplement, not modify the terms and conditions of Mayfran's order acknowledgment and/or signed contract with the customer.

SAFETY INFORMATION

DO NOT operate any machinery without reading and understanding this manual completely.

DO NOT operate any machinery unless fully trained and qualified by the owner or end user.

DO NOT operate any machinery (or any portion of this machinery) unless all personnel are clear of any rotating or moving parts (or parts that may potentially move or rotate).

DO NOT operate any machinery unless all guards and/or emergency stops are in place and functioning as designed by Mayfran.

DO NOT operate any machinery in applications other than the specific application for which the machinery was designed.

DO NOT perform any maintenance, repairs or adjustments on this machinery without first locking out all electrical controls.

DO NOT lubricate any machinery without first locking out all electrical controls.

DO NOT clean this machinery or the areas adjacent to or below the machinery without first locking out all electrical controls.

DO NOT remove any covers or guards without locking out all electrical controls.

DO NOT perform any maintenance or repairs on power lines feeding this machinery without first locking out power at the source.

DO NOT remove or cover any warning labels.

Adjustment, maintenance, cleaning and lubrication should be carried out only by personnel trained by the owner or end user in the operation of all associated conveyors and process equipment. Personnel should be trained in OSHA compliant lock-out / tag-out and electrical safety procedures. Records of training should be maintained by the owner or end user. Records of training for the safe operation of this machinery must also be maintained. Never should adjustment, maintenance, cleaning or lubrication be performed without following proper safety procedures.

Operators should be instructed to report any impairment of guards, emergency stop, or safety switches to their supervisors.

THE SAFETY INFORMATION CONTAINED HEREIN MUST BE COMMUNICATED BY THE CUSTOMER, OWNER, OR END USER TO ALL PERSONNEL WHO WILL ACTUALLY OPERATE, MAINTAIN, REPAIR, OR ADJUST THIS MACHINERY, OR WHO ARE ASSIGNED TO WORK IN THE VICINITY OF THIS MACHINERY.

SAFETY INFORMATION, continued

- **Chip Processing Equipment should be used to process only the material for which it was specifically designed.**
- **Casings, guards and other safety devices shall not be removed, bypassed, or disengaged during system operation.**
- **Personnel should not climb on the components of a system unless the equipment is expressly designed to support people and function as a work area.**
- **Only trained operators should be permitted to operate the Chip Processing Equipment.**
- **All necessary guards, switches and other safety devices shall be installed so that a loss of power to the equipment shall not render the guards, switches or safety devices inoperative.**
- **Emergency controls shall be installed so that they cannot be overridden from other locations.**
- **Guards shall be kept in place at all times unless the electrical power is off and the system is locked out.**
- **All repairs and services shall be performed by qualified personnel. Before repairs, tests or services are begun, all power controls shall be locked out in accordance with OSHA compliant procedures.**
- **After a machine has been repaired, tested or serviced, it shall not be operated until all guards and safety devices have been reinstalled, all maintenance equipment has been removed and a visual inspection of the machine and immediate area has been completed.**
- **Material should not be discharged onto a screw feed conveyor that is not operating. Material accumulations may inhibit the equipments safe operation.**
- **When working on the Chip Processing Equipment, be sure to turn the electrical disconnect OFF and LOCK OUT the power to the equipment.**

MAYFRAN INTERNATIONAL, INCORPORATED WILL NOT BE RESPONSIBLE FOR ANY WORK PERFORMED, OR ALTERATIONS MADE TO ANY OF ITS PRODUCTS UNLESS PRIOR APPROVAL HAS BEEN GRANTED BY AN AUTHORIZED MAYFRAN REPRESENTATIVE. ANY SUCH WORK PERFORMED WILL VOID ANY AND ALL WARRANTIES AND LIABILITIES. ALL WARRANTIES AND LIABILITIES SHALL ALSO BE VOID IF PARTS UNIQUE TO MAYFRAN INTERNATIONAL ARE PURCHASED FROM A SOURCE OTHER THAN MAYFRAN INTERNATIONAL.

START UP

Before the conveyor is started, the following items should be checked to ensure proper operation of the conveyor.

- 1.) Check the interior of the conveyor for obstructions such as wooden shipping braces etc. that may have gotten in during shipment. Remove all obstructions.
- 2.) Check for proper belt adjustment. See the “ **BELT ADJUSTMENT** ” section of this manual for tensioning requirements and adjustment instructions.
- 3.) Check belt direction. The lower strand of belt should be moving in a direction that is towards the head shaft. Conversely, the upper strand will be moving away from the head shaft , or towards the tail shaft. If the belt is traveling in the wrong direction, reversing any two leads on the motor will reverse its direction. See figure #1.

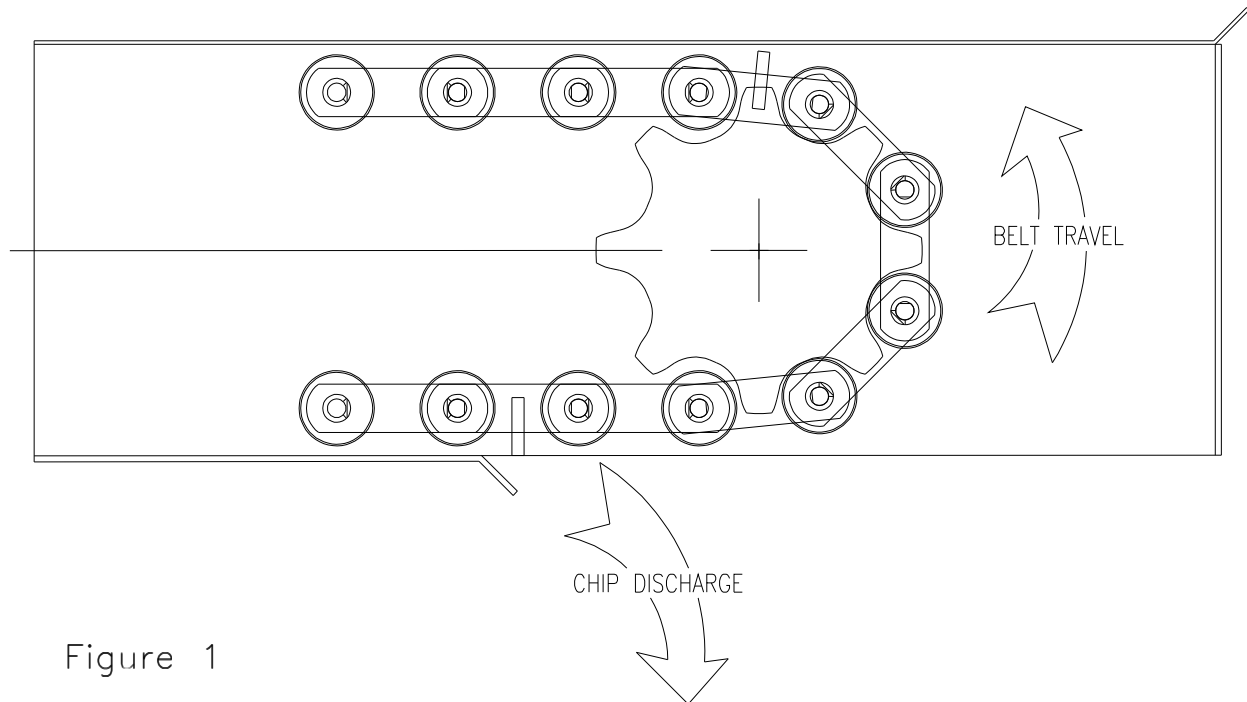

- 4.) Check for the breather plug in the gear reducer drive. It should be in the upper most port on the reducer and it should be open to atmosphere.

MAINTENANCE & ADJUSTMENTS

MAINTENANCE SCHEDULE

By far, the most important maintenance activity is to keep the conveyor clean. Cleaning the conveyor on a regular basis will ensure that the reducer, motor and electronic motion sensor will perform as they were designed. It is recommended that the end users maintenance manager produce their own preventative maintenance schedule based on the following chart. Accurate records of any maintenance performed must be kept. This table is not all inclusive, and should be used as a general guideline only. It should be adjusted for shift usage, and environmental conditions.

<u>MAINTENANCE OPERATION</u>	<u>INTERVAL</u>
Inspect drag cleats/wipers for wear or damage	Weekly
Check for proper belt adjustment	Monthly
Oil drive chain and sprockets	Monthly
Check belt tracks for material build-up	Quarterly
Clean face of motion sensor	Quarterly
Grease headshaft bearings	Semi-Annually (no.2 lithium based grease)
Check reducer oil level-change if required*	Semi-Annually, change every 2500 hrs of operation

*Note: Change oil in reducer after initial 40 hrs. of operation

LUBRICATION

A vital maintenance item is to ensure that the drive components are kept well lubricated. This will help prevent unnecessary down time due to early failure.

GENERAL LUBRICATION GUIDELINES

1. Use grease from tightly sealed containers. Grease should be free from impurities such as dirt, metal particulate or moisture.
2. Wipe grease fittings clean before adding grease.
3. A small amount of grease at frequent intervals is more preferable than a large amount at longer intervals. However, the proper amount and interval can only be determined by experience.
4. Bearings should be greased with a white lithium based grease such as Mobilux EP-2, Texaco Molytex 2 or equal. Do not mix different types of grease. Mixing grease may cause chemical reactions that diminish the greases ability to lubricate the bearings. Use one manufacturer and stay with that brand.

GEAR REDUCER

LUBRICATION

The reducers will be filled to the proper level with lubricant when shipped from the factory. However, the oil level should be checked periodically. Also, when checking the oil level, make sure that the vent plug is clean and functioning properly. The lubricant should be changed every 6 months or 2500 hours of operation. In unusually severe or harsh environments, the lubricant should be changed on a more frequent basis. The unit holds approximately ½ pint of oil.

<u>REDUCER LUBRICATION CHART</u>		
<u>MANUFACTURER</u>	<u>AMBIENT TEMPERATURE</u> 15°- 60°F AGMA Compound No.7	<u>AMBIENT TEMPERATURE</u> 50°-125°F AGMA COMPOUND NO.8
Amoco Oil Co.	Worm Gear Oil	Cylinder Oil #680
Chevron Usa, Inc.	Cylinder Oil #460x	Cylinder Oil #680x
Exxon Co. Usa	Cylesstic Tk-460	Cylesstic Tk-680
Gulf Oil Co.	Senate 460	Senate 680d
Mobil Oil Corp.	600w Super	Extra Hecia Super
Shell Oil Co.	Valvata Oil J460	Valvata Oil J680
Sun Oil Co.	Gear Oil 7c	Gear Oil 8c
Texaco	Honor Cylinder Oil	650t Cylinder Oil
Union Oil of California	Steaval A	Worm Gear Lube 140

ADJUSTMENTS

The drag conveyor requires only a few simple adjustments to keep it operating at peak performance.

BELT CHAIN ADJUSTMENT

Proper belt chain tension is critical to the reliable operation of this conveyor. The belt chains will loosen up after the initial run-in period, and after long periods of continued use as components begin to wear. A sure sign of an improperly tensioned belt chain is an observed jerking motion of the chains or cleats while running. Loose belt chains may jam and cause damage to the conveyor. Over-tightened belt chains may cause excessive wear to the belt components, and create overloads on the drive.

To determine if the belt chains are properly adjusted, do the following:

- 1.) Position a cleat several inches prior to the headshaft in the direction of belt travel.
- 2.) Disconnect and lockout all power to the equipment.
- 3.) Press up from the underside of the conveyor firmly on the center of the cleat. Observe one of the following conditions:
 - 3a.) If the cleat and chains collapse and stay collapsed, the chains are too loose.
 - 3b.) If the cleat and chains spring back to their original position, the tension is correct.
 - 3c.) If the cleat is unable to be depressed, the chains are too tight.

TIGHTENING THE BELT CHAINS

- 1.) Remove the clutch guard cover from the drive. Loosen the clutch guard back plate to allow for movement.
- 2.) Loosen the motor base mounting and adjustment bolts, and slide the base back to put some slack in the drive chain.
- 3.) Loosen the bearing mounting bolts slightly. Do not remove.
- 4.) Loosen the jam nuts on the take up bolts. Adjust the bolts inward to push on the bearing plates to tighten the belt chains. Adjust the bolts evenly on each side until condition "3b" is met above.
- 5.) Check headshaft for squareness to the machine. To do this, measure from the headshaft to the end of the head frame on each side. The dimensions should match.
- 6.) Tighten jam nuts on the take up bolts, and the bearing mounting bolts.
- 7.) Adjust the drive chain.
- 8.) Adjust the clutch guard back plate so the clutch is centered in the large opening, and the reducer shaft is centered in the slot. Tighten in place.
- 9.) Replace the clutch guard.

LOOSENING THE BELT CHAINS

Follow the above steps except step (4) four should read:

- 4.) Loosen the jam nuts on the take up bolts. Adjust the bolts outward to relieve pressure from the bearing plates to loosen the belt chains. Adjust the bolts evenly on each side until condition "3b" is met above.
- 3.) Loosen the belt chains slightly. Remove the cotterpin from the belt pin. Using a punch of less than 3/8" dia., carefully tap the pin from the chain. Perform this same procedure on the opposite side belt chain. Chains should now be separated.
- 4.) Remove the clutch guard cover. Locate drive chain masterlink and separate chain.
- 5.) Loosen the two set screws holding the clutch onto the head shaft. Pull clutch from shaft.
- 6.) Remove the mounting bolts holding the headshaft assembly to the slotted take up angles. Headshaft can now be removed from the take up slots. Do not lose the bearing push plates.
- 7.) Install new head shaft assembly, and reassemble the conveyor in reverse order.

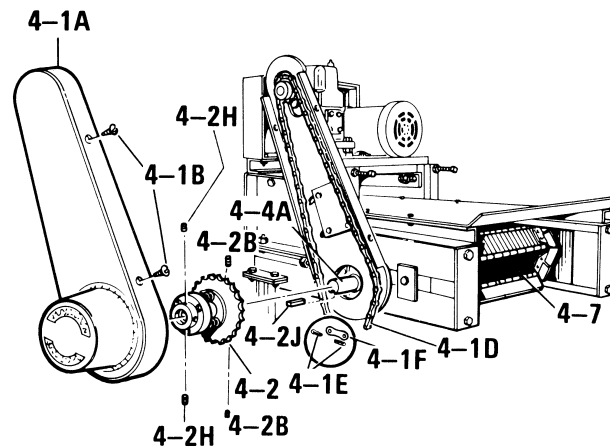

SPARE PARTS LIST

ITEM	QTY	DESCRIPTION	LENGTH	WIDTH	WEIGHT	PART NUMBER
1	1	MOTOR				
2	1	V-BELT				
3	1	REDUCER				
4	1	SPRING CLUTCH				
5	1	TAIL SHAFT ASSEMBLY				
5A	2	TAIL BEARINGS				
8	2	HEADSHAFT BEARINGS				
8A	1	HEADSHAFT ASSEMBLY				
7	1	DRIVE SPRINGSET				

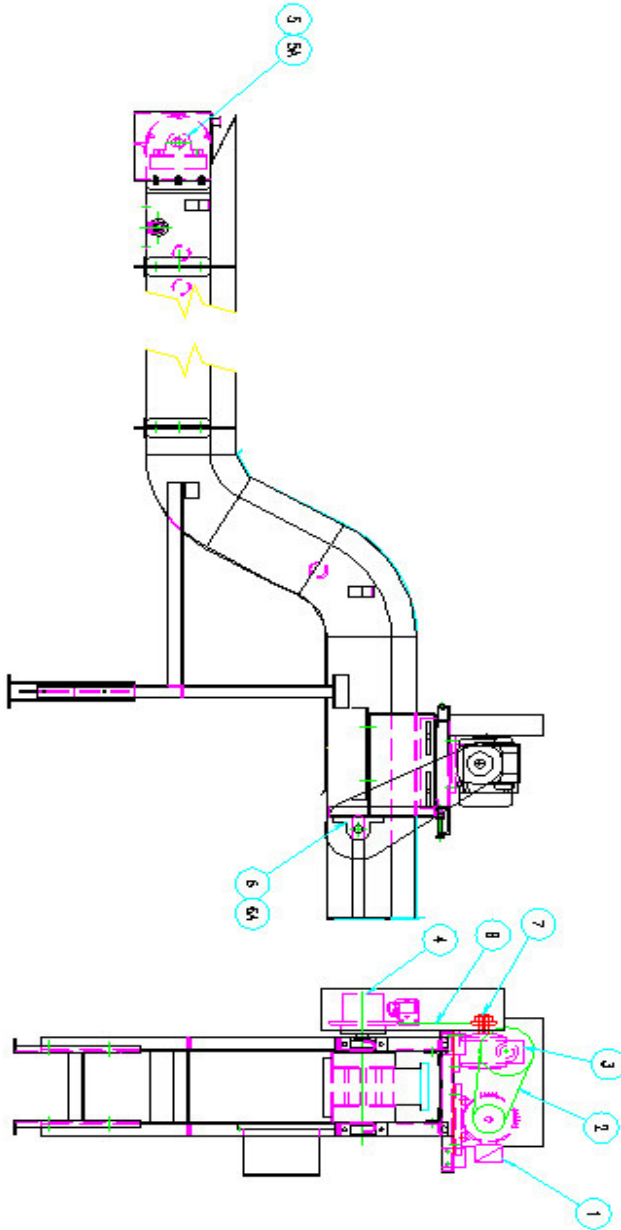

TROUBLESHOOTING

OVERVIEW

Mayfran drag conveyors are designed to be the most reliable in the industry. However, problems may arise from time to time. Problems are normally discovered in one of two ways:

A fault is indicated on the main control panel.

The second indication that a problem exists is simply by the operator noticing that there is something different about the way the conveyor is operating; usually some sort of unusual noise or vibration. The only way to correct this problem is to examine the conveyor and determine the source.

It is imperative that any unusual noises or situations are identified, diagnosed, and corrected immediately to prevent serious damage from occurring.

OVERLOAD FAULTS

An overload fault is caused by tripping the overload device that supplies power to the system component. After the overload device is reset, and any obvious cause corrected, the component should be run in manual mode, and the amperage draw on the motor checked. Also, check the current setting on the overload device.

<u>PROBLEM</u>	<u>POSSIBLE CAUSE</u>	<u>SOLUTION</u>
Motor does not start	Main power switch is not connected Emergency stop button is working Circuit breaker/overload is working	Connect power Reset emergency stop button Reset circuit breaker. Find cause of overload
Motion sensor alarm sounds	Clutch overload caused by material build up in the conveyor Loose belt chains jammed causing clutch overload Drive component failure	Remove excess material. Replace clutch if needed Retension belt chains Replace clutch if needed Investigate drive components for defective part(s)
Excessive amperage draw or motor overload trips	Belt chains too tight Excessive material jammed in belt chain or chain path	Retension belt chains Clean chain and/or chain path
Excessive jams without material blockage	Loose belt chains	Retension belt chains

All information provided in this manual is for the purpose of customer education only, and is subject to change without notice.